

Clarke®



weld



ARC ACTIVATED HEADSHIELD

MODEL NO: GWH8

PART NO: 6000714

OPERATION & MAINTENANCE INSTRUCTIONS

UK
CA | CE



ORIGINAL INSTRUCTIONS

GC08/23

INTRODUCTION

Thank you for purchasing this CLARKE Headshield. Before attempting to use this product, please read this manual thoroughly and follow the instructions carefully. In doing so you will ensure the safety of yourself and that of others around you, and you can look forward to your purchase giving you long and satisfactory service.

GUARANTEE

This product is guaranteed against faulty manufacture for a period of 12 months from the date of purchase. Please keep your receipt which will be required as proof of purchase.

This guarantee is invalid if the product is found to have been abused or tampered with in any way, or not used for the purpose for which it was intended.

Faulty goods should be returned to their place of purchase, no product can be returned to us without prior permission.

This guarantee does not effect your statutory rights.

TECHNICAL DATA

Viewing field (W x H)	100 X 93 mm
Shade available in Light State	DIN4
Shade available in Dark State	DIN 5-9 / 9-13
UV/IR protection	Max shade DIN16
Operating temperature range	-5°C - +55°C
Weight	0.56 kg
Switching time from light to dark	1/25,000 second or 0.04 m/s
Delay time from dark to light	0.15 - 0.08 second
Lens power control	Manual step-less control
Power supply	Solar Cells / Lithium Battery type Cr2032
Construction material	Plastic (nylon)

SAFETY PRECAUTIONS

This mask is not suitable for laser welding, laser cutting or overhead welding applications or for oxy-acetylene.

- The protective plate in this headshield is breakable and will not protect against impact hazards.
- This headshield is designed for use in grinding, arc welding or cutting applications such as MIG/MAG, TIG, MMA, Plasma Arc, and Carbon Arc.
- Use this headshield for face and eye protection against harmful rays, sparks and spatter from welding and cutting.
- NEVER place this product on a hot surface.
- In the event of failure, the headshield gives protection against UV and IR radiation.
- DO NOT make any modifications to this product. Protection can be seriously impaired if modifications are made.
- When necessary, use identical replacement parts. This will ensure that the safety of the product is maintained.
- DO NOT use without the protective plate installed. DO NOT use if any part of the headshield is cracked or broken.
- DO NOT use this headshield for welding outside the range of DIN 9-13. Harm to the eyes and impaired eyesight may result. Always select the correct setting before use.

ENVIRONMENTAL RECYCLING POLICY



Through purchase of this product, the customer is taking on the obligation to deal with the WEEE in accordance with the WEEE regulations in relation to the treatment, recycling & recovery and environmentally sound disposal of the WEEE.

In effect, this means that this product must not be disposed of with general household waste but according to the laws governing Waste Electrical and Electronic Equipment (WEEE) at a recognised disposal facility.

The light source contained in this worklight has a life expectancy of approximately 30,000 hours after which the worklight should be disposed of in an environmentally responsible way.

The Lithium Ion battery falls under the Waste Batteries and Accumulators Regulations 2009 and should be disposed of in a controlled manner.

PREPARATION

ADJUSTING THE HEADBAND TO FIT

1. The headband should be adjusted both in diameter and height to fit the wearer's head. To do this, press in and turn the adjustment knob on the back of the headband either left or right to expand or contract the headband.

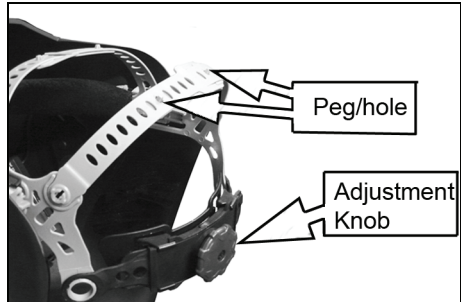

2. The top headbands can be adjusted by bending the strap and positioning the pegs in the appropriate hole in each headband.

3. The working position of the headshield and its raised position can be pre-set.

4. Loosen the adjusting nuts until you can lift the adjusting tab and position it on the pins on the backing plate to set the headband range of movement. Tighten the adjusting nut when satisfied.

- You can remove the headband completely from the headshield by unscrewing the side knobs.



USING THE HEADSHIELD

1. The lens will be set to Light DIN 4 state, & you will be able to see the workpiece. The lens will automatically darken when an arc is struck.
2. Test the lens by striking an arc on the workpiece for the first time. Check also that the outer screen and lens are clean and clear at all times.
3. Change the shade setting as required using the shade adjustment knob as described on page 5. Refer to the table on page 7.

SELECTING WELD OR GRIND SETTING

The headshield has a 'GRIND' setting, on the outside selector knob. When set to 'GRIND' the auto darkening function is disabled.

The headshield then provides eye and face protection for sparks and airborne particles created during grinding operations.

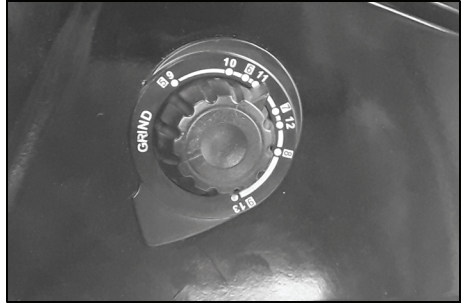

WARNING: IT IS ESSENTIAL THAT AFTER USING THE HEADSHIELD IN GRINDING MODE, IT SHOULD BE RETURNED TO THE WELD SETTING BEFORE WELDING. FAILURE TO DO THIS COULD LEAD TO EYE INJURY. MAKE A HABIT OF RETURNING THE SWITCH TO THE WELD SETTING.

DELAY TIME ADJUSTMENT

The delay time is the time taken to switch back from fully dark to fully light and is selected using the knob in the centre of the headshield.

1. Set the minimum (0.1-0.25 sec) when spot welding, or doing short or seam welding work.
2. Set the delay to medium for most welding operations.
3. Set the maximum (0.85-1.0 sec) when doing high current welding.



SENSITIVITY

The sensitivity can be adjusted using the knob on the left hand side of the headshield according to the type of welding and the background light. The mid range selection is suitable for most indoor and outdoor welding.

1. Select maximum for low current welding or when working in low light conditions, especially when welding argon arc with a low current.
2. Select minimum for high current welding or working in a brightly lit environment.

SELECT THE SHADE SETTING

WARNING: DO NOT USE FOR WELDING OUTSIDE THE RANGE OF DIN 9-13. INJURY TO THE EYES & LOSS OF EYESIGHT MAY BE CAUSED.

On striking an arc, the light created will activate the solar cell and the window will automatically darken to a preset level. The lithium battery will provide the necessary energy to operate the headshield when there is no arc light. You can adjust this shade level using the shade adjustment knob on the side of the headshield, corresponding to the type of welding process.

1. Set the shade selector to the required setting.
2. During the welding operation the lens will automatically darken to the pre-set shade. On removal of the arc, the lens will return to the light state.

Check the table to determine which you should select.

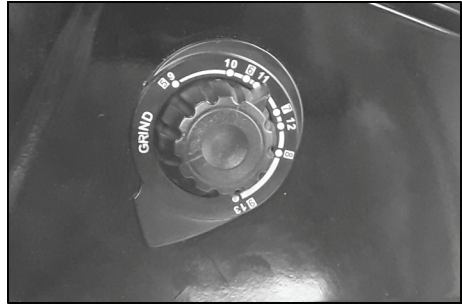

WARNING: IT IS ESSENTIAL THAT AFTER USING THE HEADSHIELD IN GRINDING MODE, IT SHOULD BE RETURNED TO THE CORRECT SETTING BEFORE WELDING. FAILURE TO DO THIS COULD LEAD TO EYE INJURY.

Shade numbers according to BS 379, DIN 4647-1 and EN 169

Welding Process	Arc Current (Amperes)																							
	0,5	1	2,5	5	10	15	20	30	40	60	80	100	125	150	175	200	225	250	275	300	350	400	450	500
Shielded Metal Arc Welding							9		10		11				12				13		14			
Metal Inert Gas (Heavy)							10				11				12				13		14			
Metal Inert Gas (Light)							10				11				12		13		14		15			
Tungsten Inert Gas Gas/Tungsten Active Gas							9		10		11		12		13		14							
Metal Active Gas/CO ₂							10		11		12		13				14		15					
Submerged-arc Welding							10						11		12		13		14		15			
Plasma-arc Cutting							11						12				13							
Plasma-arc Welding	2,5	3	4	5	6	7	8	9	10	11	12	13				14				15				

Adopt greater or smaller shade number pursuant to the field condition

CARE & MAINTENANCE

Damaged components must be replaced immediately to avoid risk of eye and face injuries. Periodically inspect the filter cartridge and lenses. Cracked, pitted or scratched lenses reduce vision and seriously reduce the level of protection and should be replaced with genuine, certified spare parts.

NEVER use sharp tools to remove foreign material sticking to the outer lens cover. This may cause damage leading to poor function and invalidate the warranty.

The outer screen can be removed for replacement and cleaning of the front lens. It sits in a groove on each side of the opening and can be prized it out by carefully inserting a suitable blade into the slot provided.

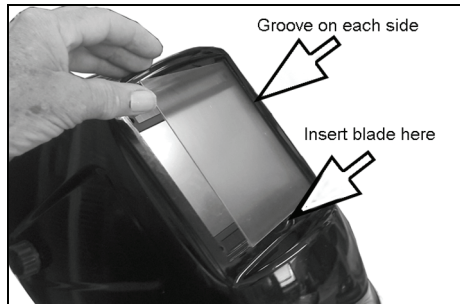

The cartridge can be wiped with a household glass cleaner when dirty. Apply the cleaner with a clean cloth or paper towel. **DO NOT USE ALCOHOL TO CLEAN. DO NOT APPLY CLEANER DIRECTLY TO THE CARTRIDGE.**

Clean all lenses with a soft tissue and suitable lens cleaning fluid. **DO NOT** use solvents. **NEVER** use tools or other sharp objects to remove material from the lens or screen. This may cause damage which may cause incorrect function and invalidate the warranty. Store the unit in its box or similar safe place.

The outer lens cover can be removed for replacement if damaged and may need replacing regularly.

- Two replacement outer lens covers are supplied with the headshield.

The inner lens cover may also require cleaning. Lift and slide the inside lens cover (on the operators side of the filter cartridge) free from the filter cartridge.

- A single replacement is supplied with this headshield.

Clean the filter surface, sensors and solar cells regularly by wiping with a household glass cleaner. Apply the cleaner with a clean cloth or paper towel. **DO NOT USE ALCOHOL TO CLEAN. DO NOT APPLY CLEANER DIRECTLY TO THE CARTRIDGE.**

Clean the headshield shell and sweat bands with detergent if necessary.

BATTERY REPLACEMENT

The batteries should last approximately 5000 hours of normal use. If the LOW BATTERY lamp comes on, the battery should be replaced.

Prise and slide the cover from the battery storage compartment.

- A small screwdriver blade will be required to remove the cover and a pair of tweezers to extract the batteries.
- 2 x CR2032 batteries are required.

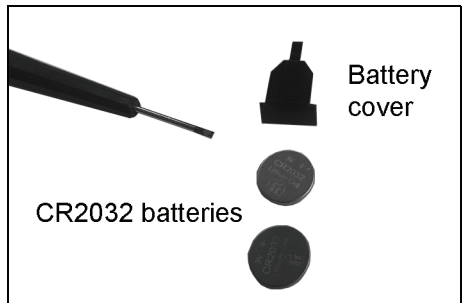
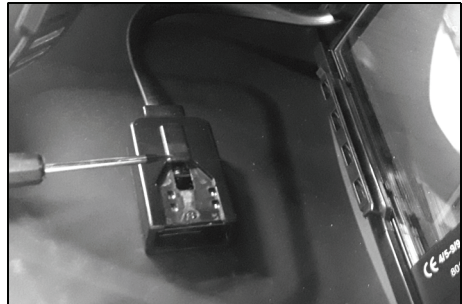
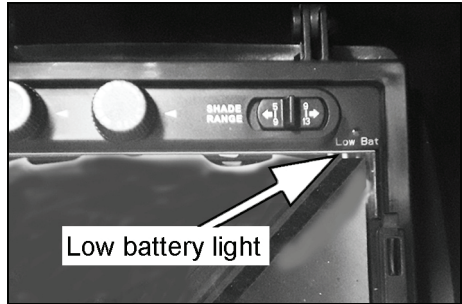

COMPONENT PARTS

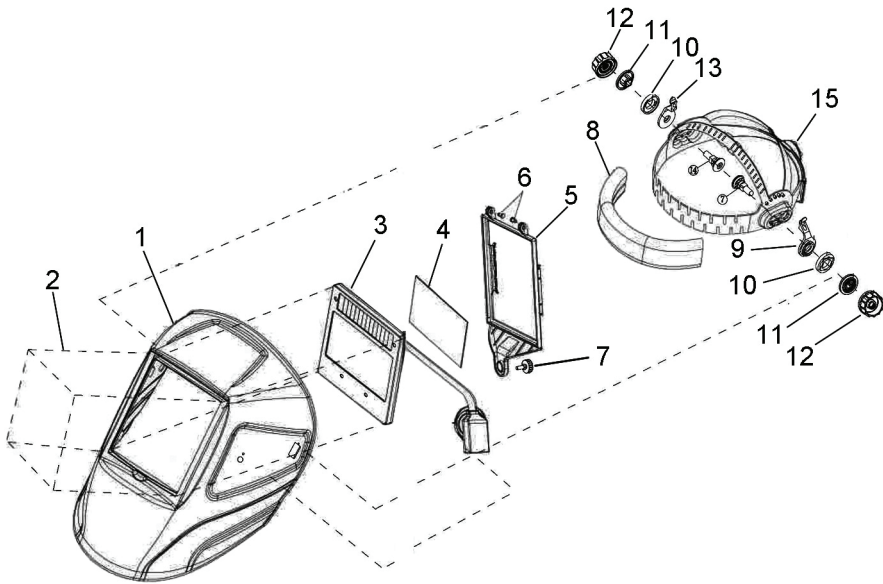

1	Shell
2	Front Cover Lens
3	Auto-Darkening Filter
4.	Inside Cover Lens
5	Frame
6	Nuts
7	Thumbscrew
8	Sweatband

9	Lefthand Tab Washer
10	Angle Adjustable Washer
11	Washer
12	Adjusting Nut
13	Righthand Tab Washer
14	Screw
15	Adjustable Headband

The GWH8 is supplied with the following;

- Small inner lens cover
- 2x Large outer lens covers

DECLARATION OF CONFORMITY -UK



DECLARATION OF CONFORMITY

This is an important document and should be retained.

We hereby declare that this product(s) complies with the following legislation: The following standards have been applied to the product(s):

- The Personal Protective Equipment (Enforcement) Regulations 2018* EN IEC 61000-3-2:2019+A1:2021, EN 61000-3-3:2013+A2:2021+AC:2022, EN 166:2001,
- The Batteries and Accumulators (Placing on the Market) Regulations 2008* EN IEC 61000-6-1:2019, EN 61000-6-3:2007/A1:2011, EN 175:1997, DIN EN 379:2009-07,
- The Electromagnetic Compatibility Regulations 2016* IEC 62321-1:2013, IEC 62321-2:2013, IEC 62321-3-1:2013, IEC 62321-5:2013,
- The Restriction of the Use of Certain Hazardous Substances in Electrical and Electronic Equipment Regulations 2012* IEC 62321-4:2013+AMD1:2017 CSV, IEC 62321-6:2015, IEC 62321-7-1:2015, IEC 62321-7-2:2017, IEC 62321-8:2017, ISO 17075-1:2017

The technical documentation required to demonstrate that the product(s) meet(s) the requirement(s) of the aforementioned legislation has been compiled and is available for inspection by the relevant enforcement authorities.

The UKCA mark was first applied in: 2023

Manufacturer:	Clarke International Ltd, Hemmell Street, Epping, Essex, CM16 4LG, United Kingdom	Notified Body:	DIN CERTCO Gesellschaft für Konformitätsbewertung mbH (ID Number: 0196), ECS GmbH (ID Number: 1883)
Product Description:	Welding Headshield	PPE Certificate:	C4883WWHIR1, C2284-3WWH, C3330-1WWH
Model Number(s):	GWH8	PPE Assessment Category:	I
Serial/Batch Number:	Refer to product/packaging label	PPE Assessment Module(s):	A
Date of Issue:	18/08/2023	Signed:	 J.A. Clarke Director

DECLARATION OF CONFORMITY - CE



DECLARATION OF CONFORMITY

This is an important document and should be retained.

We hereby declare that this product(s) complies with the following legislation: The following standards have been applied to the product(s):

2016/425	Personal Protective Equipment (PPE) Regulation	EN IEC 61000-3-2:2019+A1:2021, EN 61000-3-3:2013+A2:2021+AC:2022, EN 166:2001,
2006/66/EC	Battery Directive	EN IEC 61000-6-1:2019, EN 61000-6-3:2007/A1:2011, EN 175:1997, DIN EN 379:2009-07,
2014/30/EU	Electromagnetic Compatibility Directive	IEC 62321-1:2013, IEC 62321-2:2013, IEC 62321-3-1:2013, IEC 62321-5:2013,
2011/65/EU	Restriction of Hazardous Substances (RoHS) Directive	IEC 62321-4:2013+AMD1:2017 CSV, IEC 62321-6:2015, IEC 62321-7-1:2015, IEC 62321-7-2:2017, IEC 62321-8:2017, ISO 17075-1:2017

The technical documentation required to demonstrate that the product(s) meet(s) the requirement(s) of the aforementioned legislation has been compiled and is available for inspection by the relevant enforcement authorities.

The CE mark was first applied in: 2023

Manufacturer:	Clarke International Ltd, Fitzwilliam Hall, Fitzwilliam Place, Dublin 2, Republic of Ireland	Notified Body:	DIN CERTCO Gesellschaft für Konformitätsbewertung mbH (ID Number: 0196), ECS GmbH (ID Number: 1683)
Product Description:	Welding Headshield	PPE Certificate:	C4883WWH/R1, C2284-3WWH, C3330-1WWH
Model Number(s):	GWH8	PPE Assessment Category:	I
Serial/Batch Number:	Refer to product/packaging label	PPE Assessment Module(s):	A
Date of issue:	18/08/2023	Signed:	J.A Clarke Director

A SELECTION FROM THE VAST RANGE OF

Clarke®

QUALITY PRODUCTS



AIR COMPRESSORS

From DIY to industrial, Plus air tools, spray guns and accessories.

GENERATORS

Prime duty or emergency standby for business, home and leisure.

POWER WASHERS

Hot and cold, electric and engine driven - we have what you need

WELDERS

Mig, Arc, Tig and Spot. From DIY to auto/industrial.

METALWORKING

Drills, grinders and saws for DIY and professional use.

WOODWORKING

Saws, sanders, lathes, mortisers and dust extraction.

HYDRAULICS

Cranes, body repair kits, transmission jacks for all types of workshop use.

WATER PUMPS

Submersible, electric and engine driven for DIY, agriculture and industry.

POWER TOOLS

Angle grinders, cordless drill sets, saws and sanders.

STARTERS/CHARGERS

All sizes for car and commercial use.

PARTS & SERVICE:

0208 988 7400

Parts Enquiries

Parts@clarkeinternational.com

Servicing & Technical Enquiries

Service@clarkeinternational.com

SALES: UK 01992 565333 or Export 00 44 (0)1992 565335

Clarke INTERNATIONAL Hemnall Street, Epping, Essex CM16 4LG
www.clarkeinternational.com